

# Installation Manual

## Smart Hybrid Battery Enclosure BCL0096 V1.0



**Notice of copyright**

GoodWe Smart Hybrid Battery Enclosure Installation Manual 2017 by GoodWe Technologies. All Rights Reserved. This work is copyright, apart from any use permitted under the Copyright Act 1968. No part may be reproduced by any process, nor may any other exclusive right be exercised without the permission of GoodWe Technologies Limited.

**Privacy notice**

GoodWe will use the information provided only for warranty purposes. Without this information we will not be able to process your warranty claim. If you require further information about our privacy policy please visit our website at [goodwe.com](http://goodwe.com).

## Table of contents

Parts List .....	4
Tools required .....	4
Location and environmental requirement .....	4
Dimensions .....	5
Preparation .....	6
Mounting and enclosure .....	7
Inserting the batteries .....	7
BMS Connection .....	10
BMS battery connections table .....	11
Connecting the Battery Enclosure to the Inverter .....	12
Commissioning .....	13

## Parts List

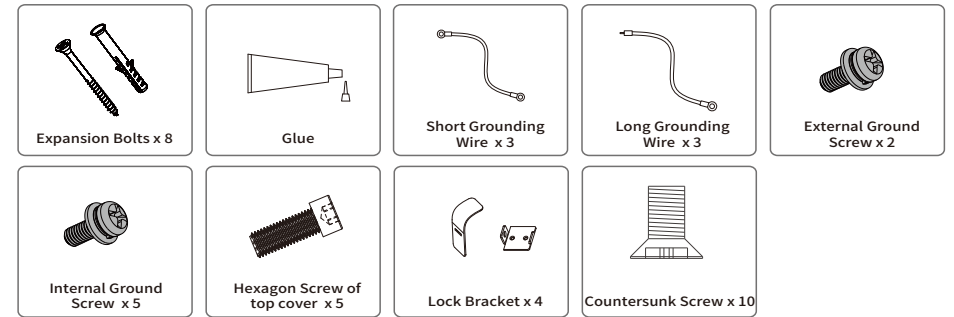

## Tools required

- . Spirit level
- . Battery drill with Phillips tec bit
- . Assorted screw drivers
- . Allen key set

## Location and environmental requirement

- . The Battery Enclosure is rated IP54, so it can be installed both indoors and outdoors.
- . If installed outdoors, the enclosure should not be mounted on a east or west ward facing wall or any location that exposes the enclosure to direct sunlight. It should also be mounted underneath a shelter to protect it from the weather.
- . The Battery Enclosure should be mounted against a reasonably flat, structurally sound wall and it needs to be standing on a level surface.
- . There should be no flood risk at the location selected for the Battery Enclosure installation.
- . There should be ample room (min 150mm) for air circulation around the Battery Enclosure as the Battery Enclosure uses fans to circulate air, the air intake and expulsion grills on the right and left hand side of the Battery Enclosure should not be blocked at any time.

## Dimensions

The Battery Enclosure dimensions are: width 535mm, depth 280mm, height 1155mm (without the feet installed) and width 535mm, depth 280mm, height 1205mm (with the feet installed).

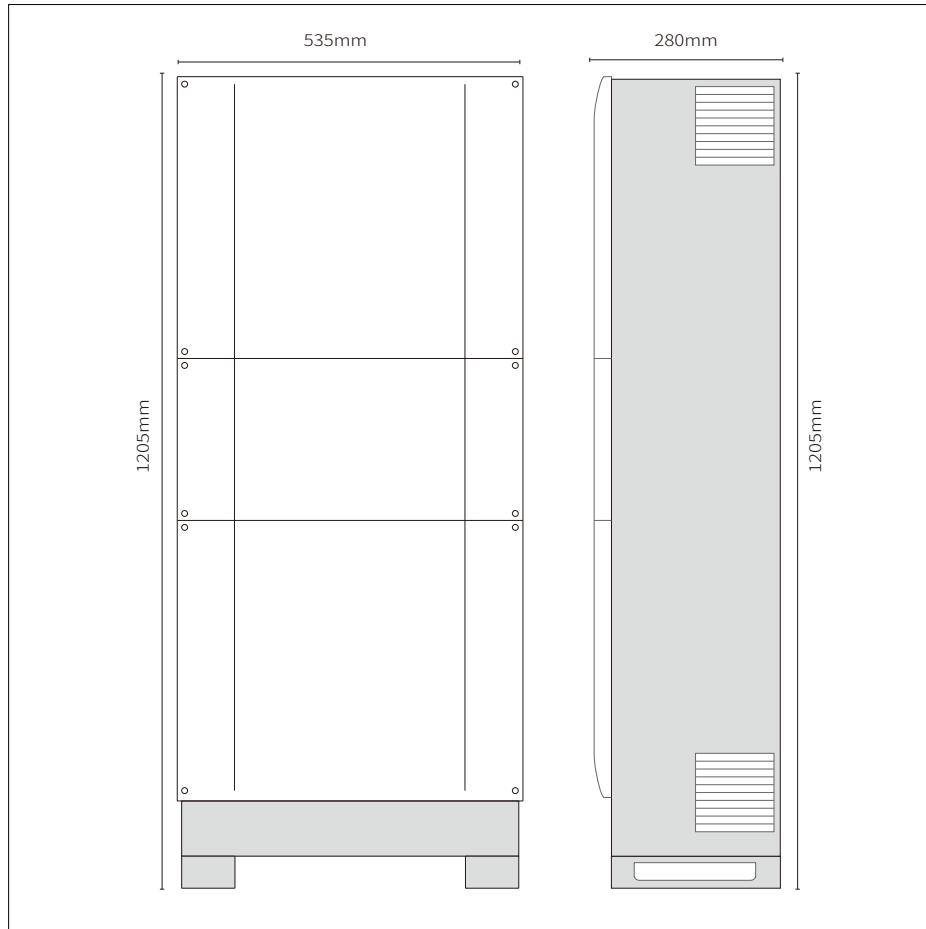

Figure 1: Dimensions

## Preparation

1. In preparation for the installation of the enclosure, take off the three front covers of the Battery Enclosure by removing the 12 screws.

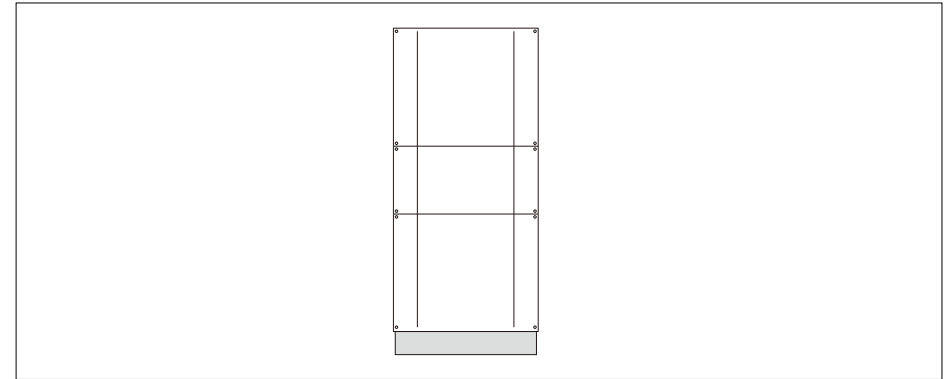

Figure 2: BCL0096 out of the packing box.

2. Screw the two feet to the base of the Battery Enclosure, using the three screws provided.

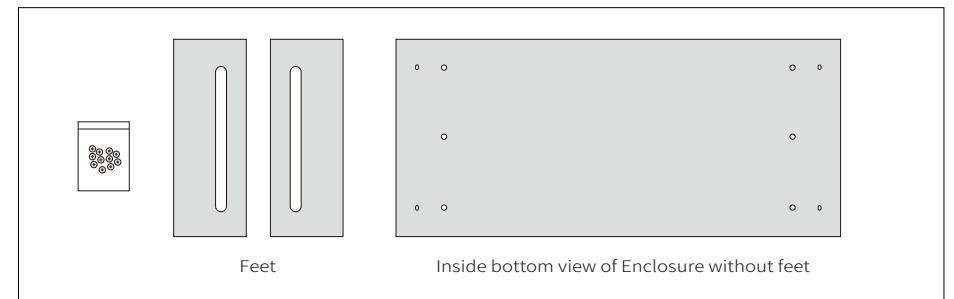

Figure 3: Battery Enclosure feet and mounting screws.

3. Once the feet are fixed, the Battery Enclosure is ready for installation as shown in Figure 4.

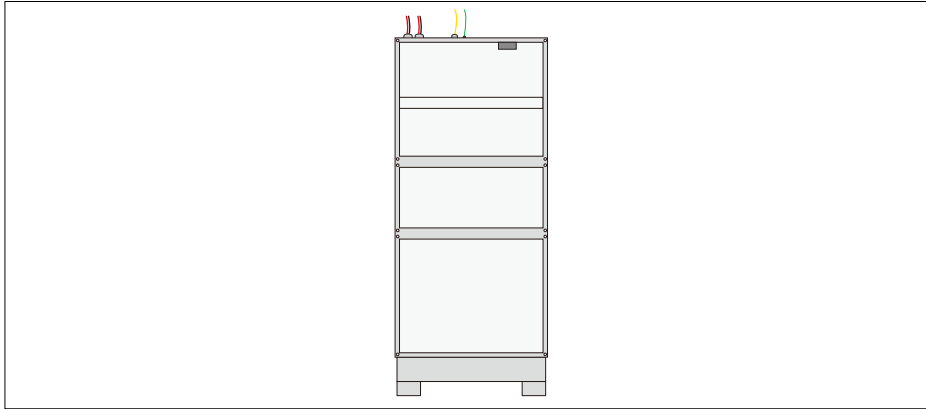

Figure 4: Battery Enclosure with the feet attached and ready for installation.

### Mounting the enclosure

The Battery Enclosure is designed to be installed below the Inverter and comes prewired for easy integration with GoodWe Inverter.

1. Set the Battery Enclosure against the wall. Ensure that the floor where the Battery Enclosure is to be installed is level.
2. Use the supplied fixing screw and plug set to fix the enclosure onto the wall. An alternative fixing mechanism can be employed if the supplied screw and plug set is not appropriate for the wall.

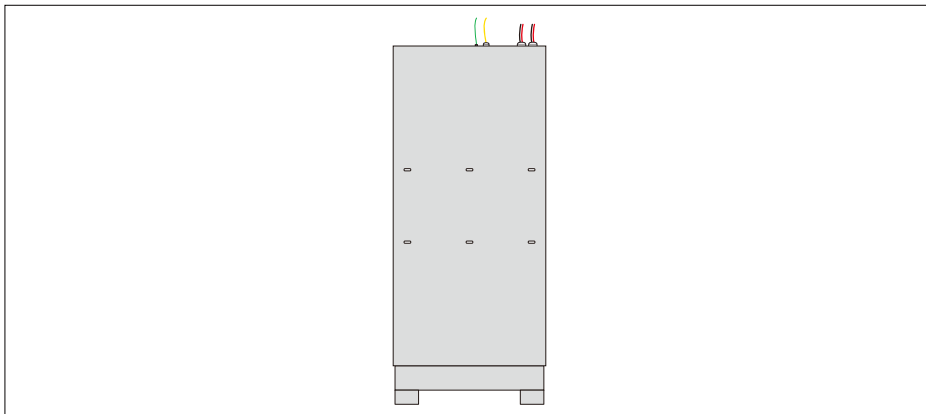

Figure 5: BCL0096 wall mounting holes.

3. Once the enclosure is fixed onto the wall, apply generous amount of the supplied sealant on the six screw holes to seal off any moisture ingress points.

### Inserting the batteries

**Note:** The battery switch should remain off during the installation process.

The enclosure can be used to house Li-ion battery types, the following installation uses GoodWe SECU-A battery as an example.

. Up to two GoodWe SECU-A (4.8kWh) battery packs with a total storage capacity of 9.6 kWh.

1. Insert the batteries onto the shelves one at a time by inserting the battery pack bottom first into the cabinet. Please fill the cabinet from bottom to top, insert battery 2 first, then 1 (see figure 8).



Figure 6: GoodWe SECU-A battery front handles.

2. Once the batteries are placed into position, plug the respective power leads into the power connectors on the batteries while taking note of the polarity. Ensure that the battery 2 lead which has the power connector for the Fan Controller is plugged into one of the batteries.

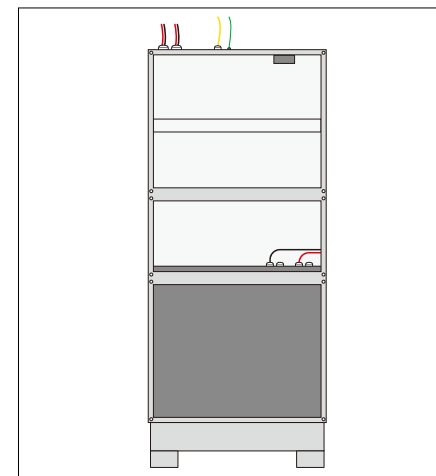

Figure 7: BCL0096 with the bottom battery inserted

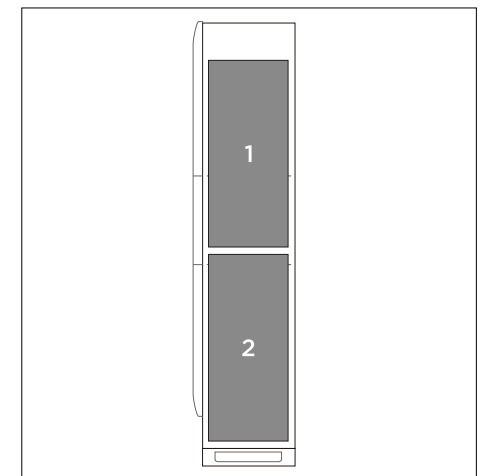

Figure 8: Inside view of BCL0096 with two GoodWe SECU-A batteries.

3.If you are using GoodWe SECU-A battery packs, connect the bonding leads between each battery and the earthing studs inside the enclosure.

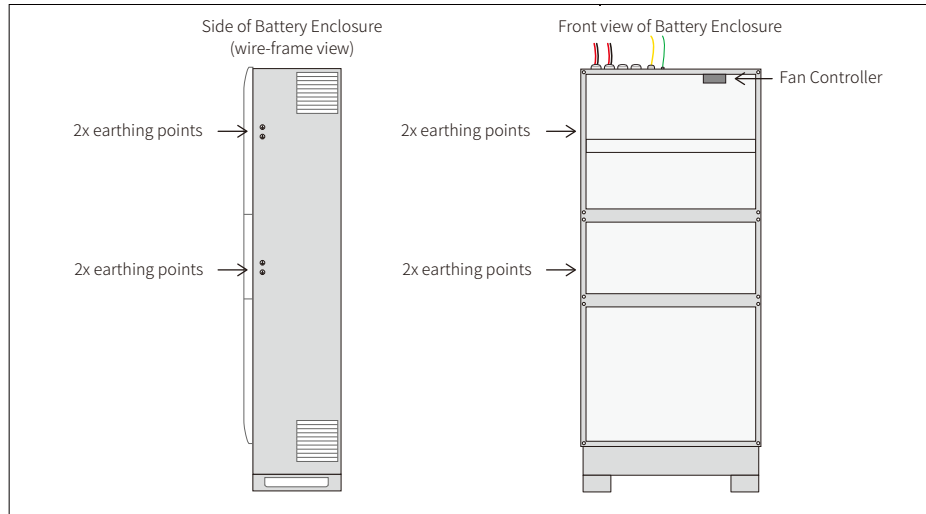

Figure 9: BCL0096 earthing connection points.

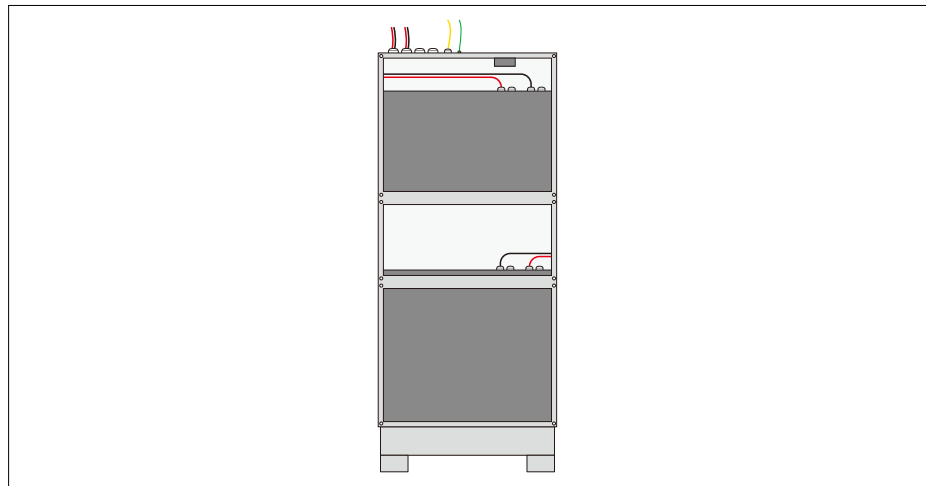

Figure 10: BCL0096 with batteries and connected (GoodWe SECU-A).

At this stage the preliminary installation of the Battery Enclosure is complete. The next step is the connection of the BMS cables.

## BMS connection

The BMS communication for GoodWe SECU-A battery is as follows:

### GoodWe SECU-A

#### DIP Switch Calibration

The DIP switches shall be configured differently between single piece battery and 2 battery paralleling system.

2\* Pack System (10.8kWh)

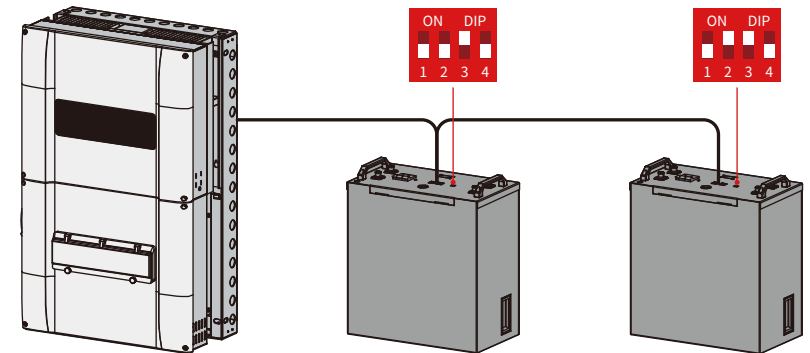

1\* Pack System (5.4kWh)

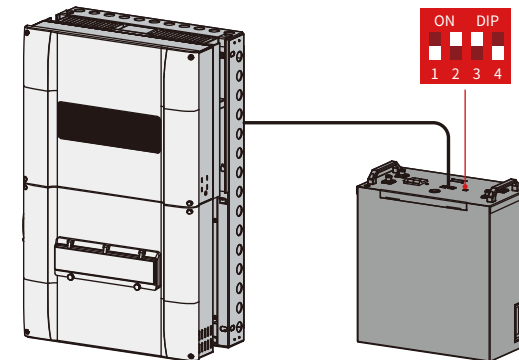

DIP	Function	Description
2	Terminal Resistance Switch	To recognize the last battery connected to inverter
3	GoodWe communication protocol Switch	To relize the communication between inverter and inverter unit part

## APP Setting (On PV Master)

To make sure the battery communicates to inverter unit successfully, users have to use PV Master to choose the right battery option on PV Master:

APP Installation And Connection:



Select Battery on PV master

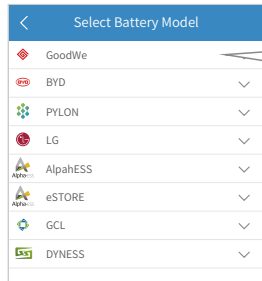

SECU-A5.4L\*1  
SECU-A5.4L\*2

Select “SECU-A5.4L” on battery page in PV Master Application

Notes:

1. Select wrong battery will lead to BMS communication failure
2. For the complete commissioning of the whole ESA system, please go to ESA instruction.

## BMS battery connection table

Description	From	To	Cable label
GoodWe SECU-A (Figure 12)	BMS feed through port	Master battery COM 1 port to Inverter port	To Inverter
	Fan Controller To Battery port	Battery 2 +/-port	Cabinet of battery
	Link Port COM 2 of the master battery	Link port COM 1 of the slave battery	Link

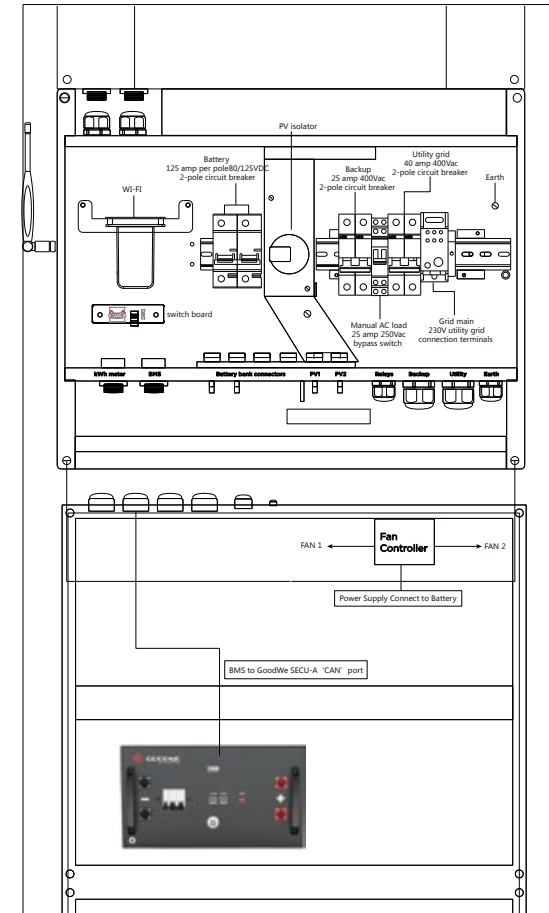

Figure 11: GoodWe SECU-A

## Connecting the Battery Enclosure to the Inverter



### CAUTION!

The inverter should be powered down during this process. Please refer to the Inverter's installation Manual for the shutdown sequence.

The Battery Enclosure is now ready to be connected to the Inverter mounted on the same wall above the Battery Enclosure as per figure 13.

Please note you should refer to the Inverter's installation manual for details on how to mount the Inverter.

1.Connect the Amphenol connectors, on the top of the Battery Enclosure, to the matching battery connectors at the base of the Inverter.

**Note:** You need to check the Inverter's commissioning steps to complete the commissioning of the whole system,

2.Connect the Battery Enclosure's earth lead to the earth terminal inside the Inverter.

3.With the Inverter's BoS box and the Battery Enclosure's front cover still open, turn on the Inverter and subsequently close the battery breaker in preparation for the commissioning process.

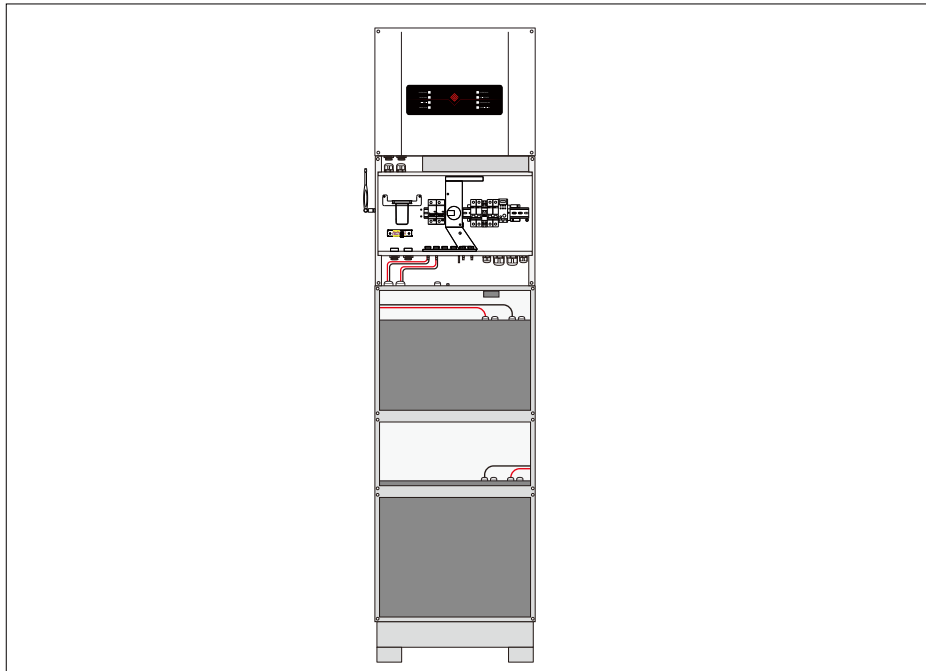

Figure 12: BCL0096 Battery Enclosure connected to Inverter (GoodWe SECU-A).

## Commissioning

### GoodWe Battery (SECU-A)

1.Ensure all the BMS connections have been done as per the instruction provided in this installation manual (page10)

2.You don't need to assign the battery (ADD) addresses manually as the master battery will do this for you (provided the BMS wiring is done per the instruction in this installation manual.

3.Press the Battery Breaker on all batteries. The green LED light should light up. (Please note that the batteries won't be discharging any power at this stage).

4.Press the Battery Switch on the master battery. That will start all batteries.

5.The 'Battery' light on the Control Board should be on, indicating that BMS communication has been established between the master battery and the Inverter and at this stage you should be able to see the battery on the portal in the APP.

**Note:** You need to check the Inverter's commissioning steps to complete the commissioning of the whole system as per the Inverter's manual.

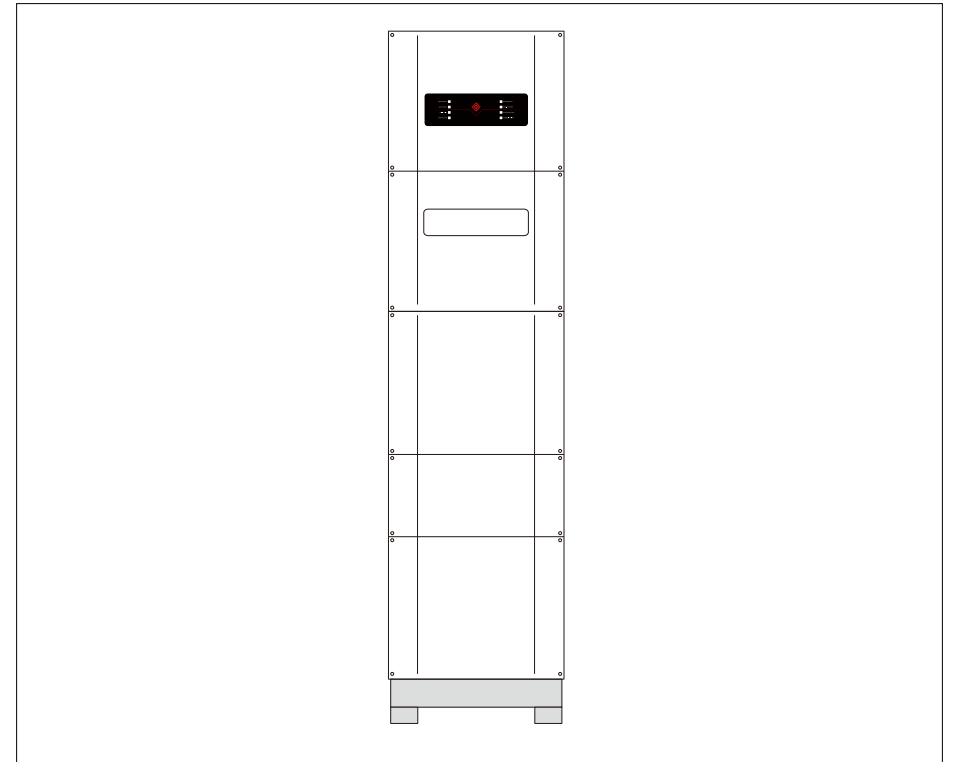

Figure 13: The completed installation of BCL0096



